

2

1

NOTES:

- 1. MATERIAL: ZNSE ZINC SELENIDE UNCOATED
- 2. SURFACE QUALITY: 40-20 SCRATCH-DIG OR BETTER
- 3. PARALLELISM: 30 ARCMINUTES MAX
- 4. TWD: $\lambda/4$ @633nm
- 5. LEAK RATE: 2×10^{-10} STD ATM CC/SEC HELIUM

B

B

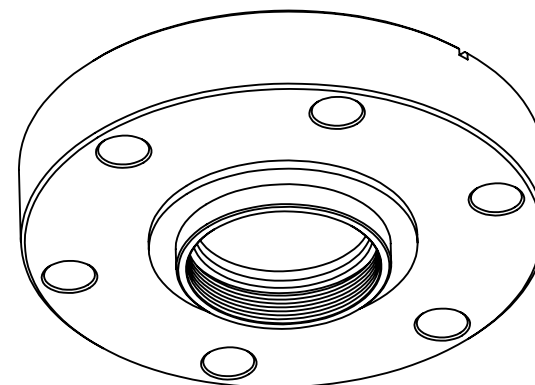
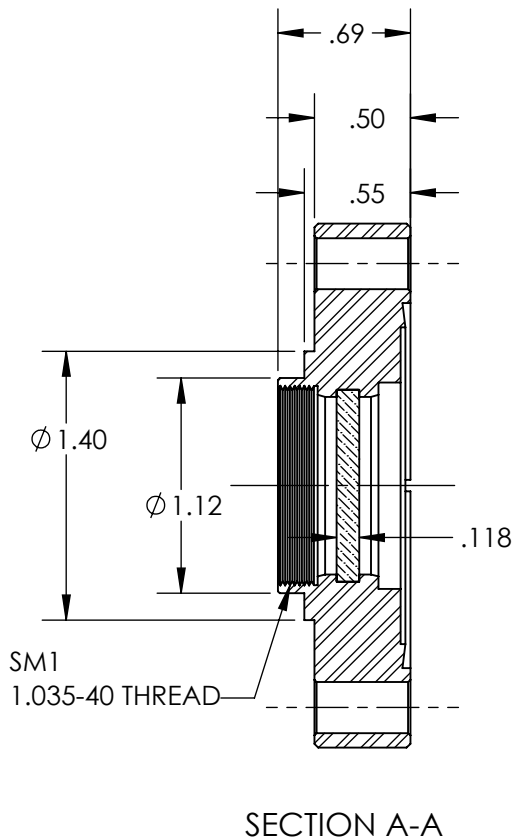
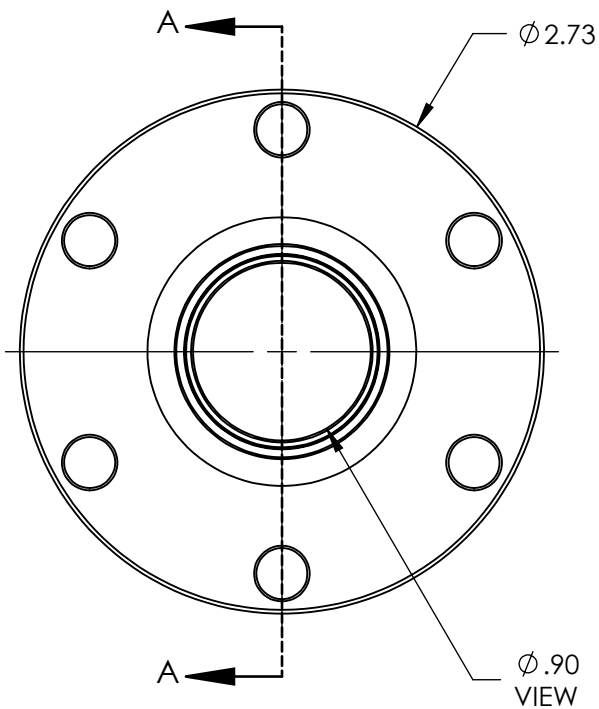

A

A

2

1