

2

1

NOTES:

- 1. MATERIAL: ZNSE ZINC SELENIDE BBAR COATED 8-12 μm
- 2. SUFACE QUALITY: 40-20 SCRATCH-DIG OR BETTER
- 3. PARALLELISM: 30 ARCMINUTES MAX
- 4. TWD: $< \lambda/4$ @633nm
- 5. LEAK RATE: 2×10^{-10} STD ATM CC/SEC HELIUM
- 6. MAGNETIC PERMEABILITY: $\mu < 1.01$

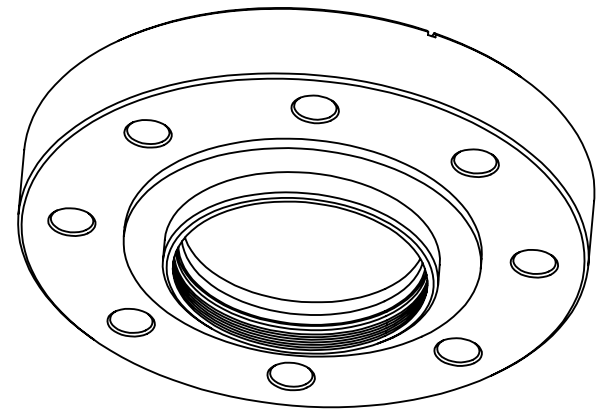
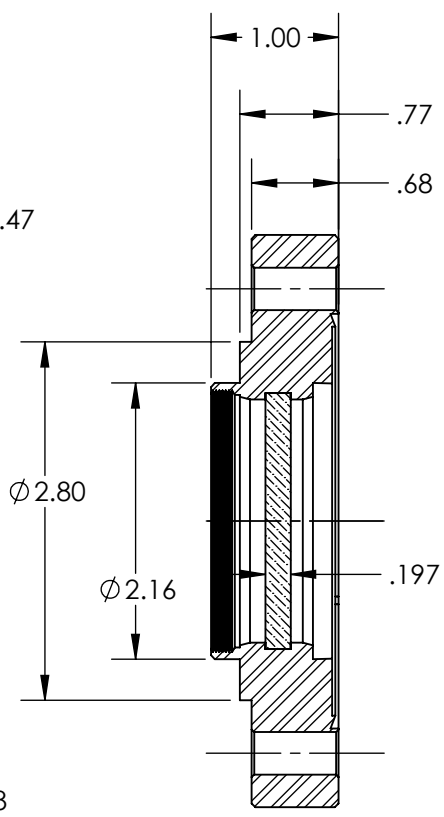
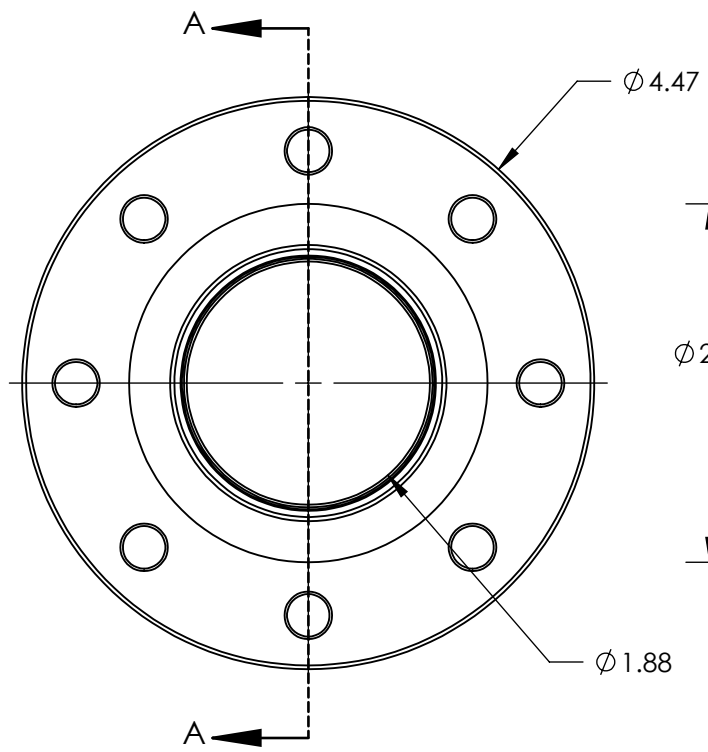

B

B

A

A

2

1